

NEW

Hydraulic Excavator JS210 LC



Engine Power: 128kW (172hp) Bucket Capacity: 0.40 – 1.19m³ Operating Weight: 21144 – 22490kg

A Product of Hard Work



Redefining excavation

Contents

Strength inside and out pages 4 – 7

Maximum productivity, minimum spend pages 8 – 11

A comfortable favourite pages 12 – 15

Less servicing, more service pages 16 – 19

The safe choice pages 20 – 22

LiveLink, knowledge is power page 23

Value added page 24

Specification pages 25 – 29





Strength
inside and out



Boom and dipper

Reinforced boom
Endurance testing
Precision engineering

Structural strength

High-strength undercarriage
Rigid upper frame
Stiff, durable door design

Componentry

Best components in the industry

BEFORE YOU BUY AN EXCAVATOR, YOU NEED TO KNOW IT'S GOING TO BE TOUGH ENOUGH TO PERFORM ANY JOB YOU ASK OF IT. FORTUNATELY, WITH A JCB JS210, STRENGTH AND DURABILITY COME AS STANDARD.



1

Boom and dipper

1 A JCB JS210's reinforced boom and dipper is made of high tensile strength steel, with single piece wrapper plates and internal baffle plates for long life durability.

2 Our advanced manufacturing and assembly processes produce high precision and quality assembled components.

Componentry

3 JCB JS210s boast the best components in the industry, including Berco running gear, Kawasaki pumps, Isuzu engine and Kayaba main control valves.



2

We use Finite Element Analysis with extensive rig and endurance testing to make key components last longer.



3



3



Structural strength

- 4 The high-strength undercarriage of a JCB JS210 uses a fully-welded X frame construction for long-term durability even in the most demanding applications.
- 5 A closed box section revolving frame increases strength and reduces stress. It is also highly resistant to impact damage.
- 6 The JS210's high-strength rigid upper frame provides maximum durability and support.
- 7 Our stiff, durable door design gives great strength and rigidity.

UNEARTHED: KEY FACT

The JCB JS210 turret is welded to both the upper and lower undercarriage frame.

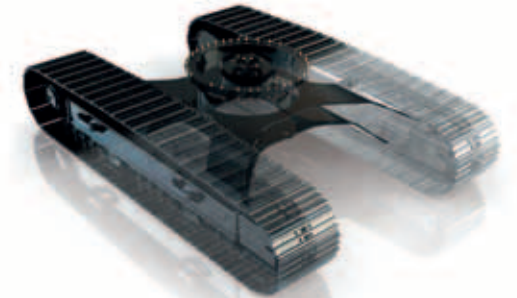

4

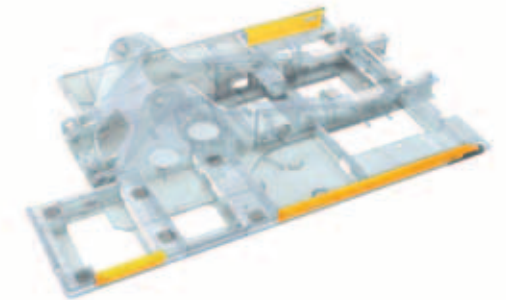

5



7



6

maximum
productivity,
minimum spend



Upping output

- 12% more productive over rivals
- Intuitive multi-function operation
- Four operating work modes

Efficiency

- Eco mode gives 11% fuel savings
- Optimised hydraulic settings

Stability, hydraulics and attachments

- Hydraulic regeneration system
- Cushioned boom and dipper ends

IT'S MORE IMPORTANT THAN EVER TO SAVE MONEY AND TIME; THE JCB JS210 RANGE IS DESIGNED TO MAKE THE MOST OF BOTH.



3

Upping output

1 With a massive 155kn bucket tearout, a JCB JS210 is up to 12% more productive than its closest competitors.

2 Simultaneous tracking and excavating is smooth and fast with an intuitive multi-function operation.

Efficiency

Advanced hydraulic technology ensures that the machines always starts in ECO mode for maximum fuel efficiency, contributing to fuel savings of up to 11%.

Optimised hydraulic pump settings and a revised spool configuration within the main valve block, only delivers the required oil flow, preventing wasted energy.

3 Tier 3 compliant Isuzu engine benefits from a revised electronic control system, delivering high torque at low revs and the highest power rated engine of 128kW (172hp) in the 20T market.



2



3

Four operating work modes allow a JCB JS210 operator to tailor performance:

AUTO: For heavy digging and high-output applications. Automatically adjusts engine speed and hydraulic flow depending on load.

ECONOMY: Gives you maximum fuel efficiency.

PRECISION: Reduces hydraulic flow and engine rpm, giving control and accuracy for fine work and grading.

LIFTING: Gives maximum power with reduced oil flow for controllability.

UNEARTHED: KEY FACT
 To save fuel, JCB Auto-Idle technology automatically reduces engine speed when hydraulics aren't in use.



Stability, hydraulics and attachments

4 JCB's innovative hydraulic regeneration system means oil is recycled across the cylinders for faster cycle times and reduced fuel consumption.

5 A JCB JS210 has cushioned boom and dipper ends to prevent shock loadings, protect your machine and increase operator comfort.

6 A JCB JS210 has a solid, stable work platform for fast cycle times.

7 JCB's quickhitch system makes attachment changing fast and easy, and is purpose-designed for the JS range.

For ultra versatility, JCB offers a full list of auxiliary pipework options including hammer, auxiliary, merged and low flow.



4



6



7

a comfortable
favourite

Comfortably in control

Intuitive controls
Choose from short or long stroke
Balanced slew

Visibly better

70/30 front screen split
Laminated glass roof



Even more benefits

Adjustable cab and controls
Minimal noise and vibration

WE'VE DESIGNED THE JCB JS210 TO BE COMFORTABLE, ERGONOMIC, SIMPLE AND INTUITIVE TO OPERATE. WHICH IS GOOD FOR YOUR OPERATORS BUT EVEN BETTER FOR YOU; AFTER ALL, GREAT EASE OF USE EQUALS GREAT PRODUCTIVITY.

Visibly better

- 1 JCB JS210s have excellent front visibility with a 70/30 front screen split and a clear view of the front right track for easy, safe trench digging and manoeuvring.
- 2 A large laminated glass roof window gives the JS210 optimum visibility for working at height.

Comfortably in control

- 3 Light, intuitive and smooth controls improve comfort and productivity.

Choose between short stroke or long stroke hand control levers for operator choice and comfort.

- 4 JCB JS210s have proportional auxiliary control options for smooth, precise control.
- 5 For even greater speed and control, a JCB JS210 has a balanced slew and electronic/hydraulic controlled slew braking.

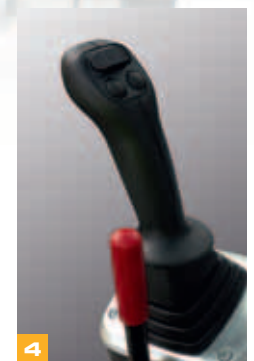



Even more comfort

6 JCB JS210s have a spacious luggage tray behind the operator's seat.

7 Function switches are easy to reach and include the heater and climate control panels, while the side unit doubles as part of the immobiliser code selector.

8 The easily-accessible Advanced Monitoring System can keep tabs on a JCB JS210's functions and inputs while different working modes are selected either manually or automatically.

9 JCB JS210 cabs use 6 viscous rubber mounts to minimise noise and vibration.

10 A large floor area with large high grip pedals give easy and precise tracking.

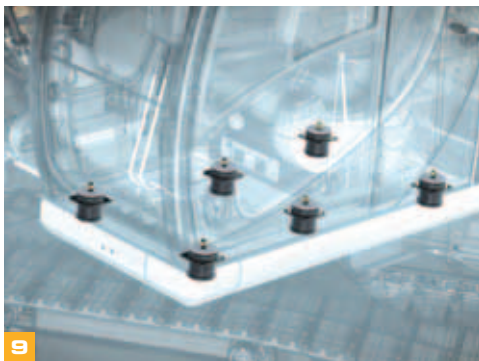

The JS210's cab and controls are independently adjustable so that it's easy to find the perfect operating position.



JCB's climate control option offers a precisely controlled cab temperature with fresh or recirculated air. Demisting/defrosting functions keep a JS210's front window clear.

**less servicing,
more.
service**



Easy does it

1000-hour boom and dipper greasing intervals

5000-hour oil life

Easily-accessible filters

Here to help

In-cab system monitoring

The best back-up in the business

Centralised grease points

Large service bays

Radiator, cooler and intercooler easily accessed

WE'VE DESIGNED JCB JS210S TO BE LOW MAINTENANCE AND EASILY SERVICEABLE. WHICH MAKES THEM AFFORDABLE, EFFICIENT AND HIGHLY PRODUCTIVE. HELPING YOU GET THE BEST SERVICE FROM YOUR MACHINE.



By using graphite impregnated bronze bushes, we've reduced the JS210's boom and dipper greasing intervals to 1000 hours for normal applications.



1

Easy does it

- 1 The air filter on a JS210 is easily accessible, and a double-element construction simplifies cleaning.
- 2 JCB's Plexus Oil Filter System extends oil life to 5000hrs by constantly filtering hydraulic fluid down to 2 microns, reducing risk of contamination.
- 3 The filters on a JCB JS210 (engine oil, hydraulic oil and fuel) are centrally located for fast, easy servicing.



2

	SERVICE INTERVALS
Engine oil and oil filter	Every 500 hours
Hydraulic oil	Every 5000 hours
Hydraulic oil filter	Every 1000 hours

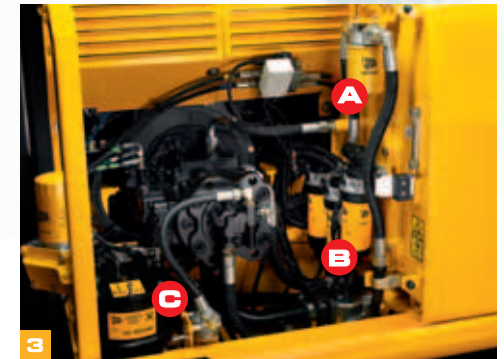

(A) Hydraulics oil filters (B) Fuel filters (C) JCB Plexus Oil Filter System



UNEARTHED: KEY FACT
JCB JS210 grease points are centralised for safe and easy access to high level pivots.

JCB JS210 bonnets open and close easily with gas-assisted cylinders, and the service bays are large and wide for good access.



4

Here to help

4 JCB's In-Cab Monitor checks engine oil levels and system errors on start-up.

5 Because they're mounted side by side on a JCB JS210, the engine radiator, hydraulic cooler and intercooler can be serviced individually yet cleaned easily.

6 Service your JCB JS210 with your local main dealer and our trained engineers can minimise downtime. Order genuine JCB parts online and, in 95% of cases, they'll be with you next day. For extra security and machine protection, opt for a package like JCB LiveLink remote machine monitoring.



5



6



6

the safe choice



Safety first

- Front-to-rear bonnet opening
- ROPS/FOPS protection
- Easily-isolated hydraulics
- Great visibility
- Anti-slip steps and platform
- Optional rear-view camera
- Optional full mirror set
- Engine/hydraulic heat shield

ON-SITE SAFETY IS CRUCIAL, SO WE'VE DESIGNED THE JS210 TO INCORPORATE AS MANY CUTTING EDGE SAFEGUARDS AS POSSIBLE. IN SHORT, YOUR OPERATORS ARE IN SAFE HANDS.

We've fitted as standard a bulk head heat shield between the pumps and the engine to guard against heat and noise.



1 JCB JS210 bonnet opens front-to-rear for easy and safe engine service access.

2 For extra peace of mind, JCB JS210 cabs are available with an integral rollover protection structure (ROPS). It's easy to fit JCB's FOPS (Falling Objects Protection Structure) to a JS210 cab, thanks to standard fitment mounting brackets.

3 JCB's Safety Lever Lock fully isolates hydraulic functions to avoid unintended movements. Our start function means a JCB JS210 can only be started in a safe locked position.

4 JCB JS210s have a large glass area and low bonnet line for superb visibility.

5 A JCB JS210's steps and platforms have anti-slip punched steel plates for optimum grip, even in wet or icy conditions. Bolt-on plates have recessed bolts to reduce trip hazard.

6 JCB's optional rear-view camera displays an uninterrupted backwards view on an in-cab colour monitor.

7 Equip your JCB JS210 with a full set of side and rear view mirrors for all-round visibility and safety compliance.



LIVELINK, KNOWLEDGE IS POWER

JCB LIVELINK IS AN INNOVATIVE SOFTWARE SYSTEM THAT LETS YOU MONITOR AND MANAGE YOUR MACHINES REMOTELY – ONLINE, BY EMAIL OR BY MOBILE PHONE. LIVELINK GIVES YOU ACCESS TO A WHOLE HOST OF USEFUL DATA, INCLUDING MACHINE ALERTS, FUEL REPORTS* AND EVENT HISTORY INFORMATION. ALL YOUR MACHINE INFORMATION IS HANDLED AT A SECURE DATA CENTRE FOR YOUR PEACE OF MIND.



Productivity and cost benefits

For ultimate productivity and cost-saving, JCB LiveLink provides information like idle time monitoring* and machine fuel consumption* to help reduce your fuel usage. Machine location information can improve fleet efficiency and you may even enjoy reduced insurance costs courtesy of the added security that LiveLink brings.

* These features require an electronic engine.

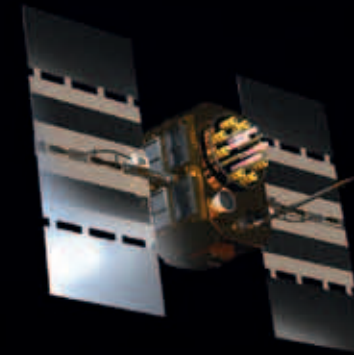
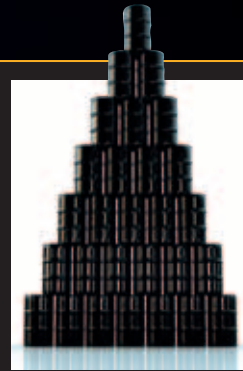

Maintenance benefits

JCB LiveLink makes it easy to manage machine maintenance. Accurate hours monitoring and service alerts improve maintenance planning, and real-time location data helps you manage your fleet. You'll also have access to critical machine alerts and maintenance history records.



Security benefits

Keep your machine operating safely with JCB LiveLink. Real-time geofencing alerts tell you when machines move out of predetermined operating zones, and real-time curfew alerts inform you if machines are being used when they're not supposed to be. Real time location information helps you store your machines in the safest places.



VALUE ADDED

JCB'S WORLDWIDE CUSTOMER SUPPORT IS FIRST CLASS. WHATEVER YOU NEED AND WHEREVER YOU ARE, WE'LL BE AVAILABLE QUICKLY AND EFFICIENTLY TO HELP MAKE SURE YOUR MACHINERY IS PERFORMING TO ITS FULL POTENTIAL.



1

1 Our Technical Support Service provides instant access to factory expertise, day or night, while our Finance and Insurance teams are always on hand to provide fast, flexible, competitive quotes.

2 JCB Assetcare offers comprehensive extended warranties and service agreements, as well as service-only or repair and maintenance contracts. Irrespective of what you opt for, our Maintenance teams around the world charge competitive labour rates, and offer non-obligation quotations as well as fast, efficient insurance repair work.



3

3 The global network of JCB Parts Centres is another model of efficiency; with 16 regional bases, we can deliver around 95% of all parts anywhere in the world within 24 hours. Our genuine JCB parts are designed to work in perfect harmony with your machine for optimum performance and productivity.



2

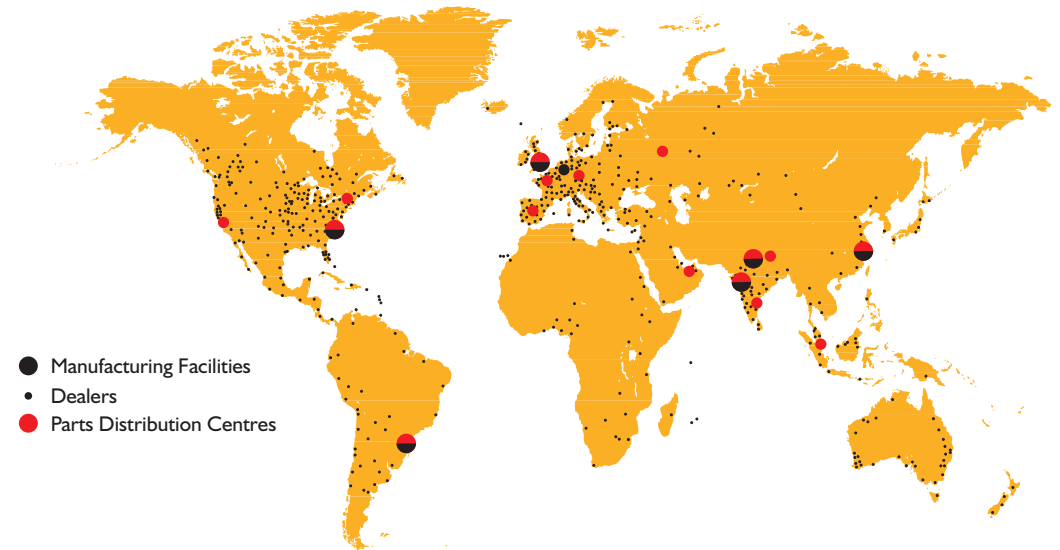

- Manufacturing Facilities
- Dealers
- Parts Distribution Centres

ENGINE

Model	Isuzu 4HKIX. European Tier III emissions compliant.
Type	Water cooled, 4-stroke, 4-cylinder in-line, direct injection, turbocharged diesel.
Nett power (ISO 3046-1NF)	128kW (172hp) at 2000rpm.
Piston Displacement	5.193 litres.
Injection	Electronic injection.
Air Filtration	Dry element with secondary safety element and in cab warning indicator.
Cooling	Water cooler via large capacity radiator.
Starter motor	24 volt – 4.5kW.
Batteries	2 x 12 volt Heavy-duty.
Alternator	24 volt 40 amp.
Refuelling pump	Electric type.

SWING SYSTEM

Swing motor	Axial piston.
Swing brake	Hydraulic braking plus automatic spring applied disc type parking brake.
Final drive	Planetary reduction.
Swing speed	12.9rpm.
Swing gear	Large diameter, internally toothed fully sealed grease bath lubricated.
Swing lock	Switchable brake in cab.

UNDERCARRIAGE

Carriage options	LC-Long Carriage.
Construction	Fully welded, "X" frame type with central bellyguarding and track motor guards. Sloping sidemembers with dirt relief holes under top rollers.
Recovery point	Front and rear.
Track type	Sealed and greased.
Track shoe options	LC – 600mm (24in), 700mm (28in), 800mm (31.5in), 900mm (36in).
Upper & lower rollers	Heat treated, sealed and lubricated.
Track adjustment	Grease cylinder type.
Track idler	Sealed and lubricated, with spring cushioned recoil.
	LC
No. of track guides	2 per side
No. of lower rollers	8 per side
No. of upper rollers	2 per side
No. of track shoes	49 per side

ENVIRONMENT

Engine emissions	Fully compliant with EU Stage III A and EPA Tier 3 exhaust emissions regulations
Noise levels	LwA external: dBA 103 LwA operator ear: dBA 72

HYDRAULICS

A variable flow load sensing system with flow on demand, variable power output and servo operated, multi-function open centre control. Machine auto warm up standard – maximises performance in cold conditions.

Pumps

Main pumps	2 variable displacement axial piston type.
Maximum flow	2 x 214 L/min (2 x 47 UK GPM).
Servo pump	Gear type.
Maximum flow	20 L/min (4.4 UK GPM).

Control valve

A combined four and five spool control valve with auxiliary service spool as standard. When required twin pump flow is combined to boom, dipper and bucket services for greater speed and efficiency.

Relief valve settings

Boom/Arm/Bucket	343 bar (4975 lbf/sq.in)
Automatic power boost	373 bar (5410 lbf/sq.in)
Swing circuit	289 bar (4190 lbf/sq.in)
Travel circuit	343 bar (4975 lbf/sq.in)
Pilot control	40 bar (580 lbf/sq.in)

A separate Cushion Control valve in the servo system provides cushioning of the boom and dipper spools selection and quick warm-up of the servo system.

Hydraulic cylinders

Double acting type, with bolt-up end caps and hardened steel bearing bushes. End cushioning is fitted as standard on boom, dipper and bucket rams.

Optional hose burst check valves available for boom and dipper rams.

Filtration

The hydraulic components are protected by the highest standard of filtration to ensure long hydraulic fluid and component life.

In tank	150 micron, suction strainer.
Main return line	10 micron, fibreform element.
Plexus Bypass line	1.5 micron, paper element.
Pilot line	10 micron, paper element.
Hydraulic hammer return	10 micron, reinforced microform element.

Cooling

Cooling is provided via a full return line air blast cooler as part of a single face cooling pack in conjunction with the engine water cooler.

TRACK DRIVE

Type	Fully hydrostatic, 3-speed with autoshift between high and medium speed.
Travel motors	Variable swash axial piston type, fully guarded within undercarriage frame.
Final drive	Planetary reduction, bolt-on sprockets.
Service brake	Hydraulic counter balance valve to prevent overspeeding on gradients.
Park brake	Disc type, spring applied, automatic hydraulic release.
Gradeability	70% (35 deg) continuous.
Travel speed	High – 5.6 km/h (3.4 mph). Mid – 3.3 km/h (2.1 mph). Low – 2.3 km/h (1.4 mph).
Tractive effort	202kN (19570 kgf, 43144 lbf).

DRIVES AND BRAKES

Steering control	Twin pedal and levers giving independent track control
Drive method	Hydrostatic
Travel operation	3-speed with automatic shift between medium and high speed
Gradeability	70% 35°
Maximum travel speeds	Low – 2.3 km/h (1.4 mph) Medium – 3.3 km/h (2.1 mph) High – 5.6 km/h (3.4 mph)
Tractive effort	202.3 kN (20629/45479 kgf/lbf)
Brake system	Hydraulically operated discs in each travel motor

EXCAVATOR END

Monoboom available along with a choice of dipper lengths to suit the requirements of reach, dig-depth, loadover height, tearouts and site versatility. Reserve strength is built into the fully welded structures for hydraulic hammer and other arduous operations. Fabricated bucket tipping links are provided with a choice of lift points. Strong, durable construction, large cross sections and multi-plate fabrications to withstand high stress applications. The 5.7m (18ft 8in) boom is designed to ensure the optimum digging envelope when matched with the three dipper lengths. Low maintenance bronze alloy bushes with graphite plugs are fitted to boom base and boom to dipper pivots resulting in 1000 hour greasing intervals at these points.

CAB

Excellent digging, loading and positioning visibility results from the careful design of front, side and roof lights. All screens are tinted to improve in cab conditions. Fully opening front screen is very smooth to operate and as the lower screen is stored within the top screen frame it makes complete front screen opening easy, fast and convenient. Fresh air ventilation available from opening door window, opening slot in front screen and fully opening front screen. Parallelogram wash wiper for upper screen ensuring good wiped area for maximum visibility. Wiper motor is fitted in the left hand side of the roof screen so as not to affect bucket visibility when loading. Optional lower screen wiper available. Fresh air ventilation and heater with windscreen demister. Infinitely variable blower speed, temperature and recirculation control. Optional climate control. Fully adjustable deluxe suspension seat with arm rest adjustment and backrest recline. Optional radio with digital tuner fitted into the roof lining for maximum protection. Conveniently placed radio mute button incorporated into lower console. 12v power point and mobile phone holder built into the right hand console. Courtesy light can be operated from ground level and is illuminated for five minutes or until switched off improving operator access at night. Cab mounted roller blind protects operator from suns' glare through front or top screens.

SERVICE CAPACITIES

Fuel tank	litres (UK gal)	343 (75.4)
Radiator	litres (UK gal)	25.5 (5.61)
Engine oil	litres (UK gal)	21.5 (4.7)
Swing reduction gear	litres (UK gal)	5.0 (1.1)
Track reduction gear (each side)	litres (UK gal)	4.7 (1.0)
Hydraulic system	litres (UK gal)	200 (44)
Hydraulic tank	litres (UK gal)	120 (26.4)

AMS – ADVANCED MANAGEMENT SYSTEM

Four selectable working modes link the operators control movements with the engine and hydraulic systems to maximise productivity and efficiency.

A (Auto) Up to 100% engine power and 100% flow. Gives variable power and speed depending on the operator's input, matching the demand for output and efficiency to the job. Power boost is automatically activated in this mode should hard conditions be encountered. Auto idle cuts in after a period of inactivity (between 5 and 30 seconds as set by the operator)

E (Economy) 80% engine power. 95% of hydraulic flow maximises economy while maintaining excellent output.

P (Precision) 55% engine power. 90% of hydraulic flow for fine control of grading operations.

L (Lifting) 55% engine power. 63% of hydraulic flow with permanent power boost for maximum lifting power and control.

The Auto mode allows the AMS processor to select the optimum operational performance to match the demands of the job while the three alternative modes give precise matching of application when specific tasks are undertaken. The adjustable position monitor mounted on the front right hand pillar of the cab gives the operator a constant read out of mode, tracking range, operating temperature and a host of other information, while retaining excellent visibility of the monitor and the job being carried out. The required flow for hammer applications can be set and stored in the AMS memory and is automatically activated whenever the hammer pedal is depressed. A maintenance indicator warns of imminent service needs, and all servicing and basic checks can be carried out using only the in cab display.

CONTROLS

Excavator All servo lever operated to ISO control pattern, independently adjustable to the seat.

Tracks Individually servo operated by foot pedal or hand lever. Speed selection via joystick button.

Auxiliary Via servo operated foot pedal.

Control isolation Via gate lock lever at cab entrance or panel switch.

Engine speed Dial type throttle control plus servo lever mounted one-touch idle control or separate selectable auto-idle with adjustable time delay using AMS.

Engine stop Ignition key operated and separate shut-down button.

Horn Operated via servo lever mounted button.

STATIC DIMENSIONS

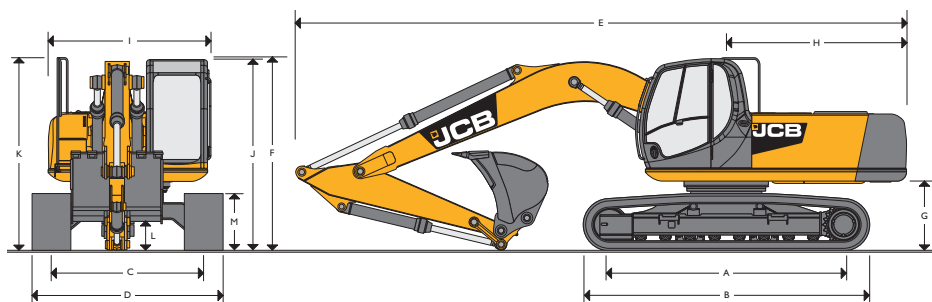

Dimensions in millimetres (ft-in)	LC
A Track length on ground	3660 (12-0)
B Undercarriage overall length	4460 (14-8)
C Track gauge	2170 (7-1 1)
D Width over tracks (600mm trackshoes)	2770 (9-1)
D Width over tracks (700mm trackshoes)	2870 (9-5)
D Width over tracks (800mm trackshoes)	2970 (9-9)
D Width over tracks (900mm trackshoes)	3070 (10-1)

Dipper lengths	1.91m (6ft 3in)	2.40m (7ft 10in)	3.0m (9ft 10in)
E Transport length with Monoboom	9570 (31-5)	9560 (31-4)	9440 (31-0)
F Transport height with Monoboom	3055 (10-0)	3060 (10-0)	3025 (9-11)

WEIGHTS AND GROUND BEARING PRESSURES

Figures include 1.14m³ bucket 760kg (1675lbs), operator, full fuel tank, 600mm track shoes and 2.4m dipper.

	JS210 Mono			
	Machine Weight		Ground bearing pressure	
	kg	lbs	kg/cm	lb/ sq ft
600mm shoes	21090	46495	0.39	5.55
700mm shoes	21355	47080	0.34	4.83
800mm shoes	21625	47675	0.30	4.30
900mm shoes	21675	47785	0.27	3.85

Dimensions in millimetres (ft-in)	LC
G Counterweight clearance	1066 (3-6)
H Tailswing radius	2825 (9-3)
I Width of superstructure	2549 (8-4)
J Height over cab	2946 (9-8)
K Height over grab rail	3025 (9-11)
L Ground clearance	486 (1-7)
M Track height	885 (2-11)

BUCKET AND ARM FORCE

Arm length		1.91m (6ft 3in)	2.40m (7ft 10in)	3.00m (9ft 10in)
Bucket digging force	kg (lb)	14550 (32080)	14550 (32080)	14550 (32080)
Bucket digging force at Power boost	kg (lb)	15800 (34835)	15800 (34835)	15800 (34835)
Arm crowd force	kg (lb)	13450 (29650)	11560 (25485)	9590 (21142)
Arm crowd force at Power boost	kg (lb)	14610 (32210)	12550 (27670)	10410 (22950)

WORKING RANGE

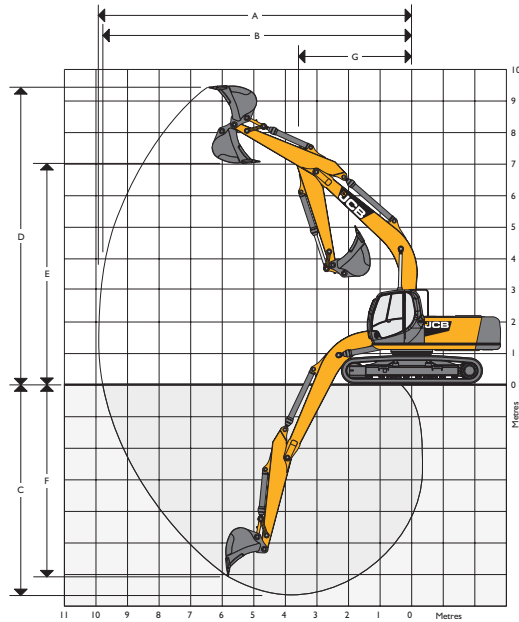

WORKING RANGE

Boom length 5.70m (18ft 8in)		1.91m (6ft 3in)	2.40m (7ft 10in)	3.00m (9ft 10in)
Dipper length				
A Maximum digging reach	m (ft-in)	8.89 (29-2)	9.34 (30-8)	9.87 (32-5)
B Maximum digging reach (on ground)	m (ft-in)	8.70 (28-7)	9.16 (30-1)	9.70 (31-10)
C Maximum digging depth	m (ft-in)	5.53 (18-2)	6.02 (19-9)	6.60 (21-8)
D Maximum digging height	m (ft-in)	8.95 (29-4)	9.20 (30-2)	9.40 (30-10)
E Maximum dumping height	m (ft-in)	6.31 (20-8)	6.53 (21-5)	6.75 (22-2)
F Maximum vertical wall cut depth	m (ft-in)	4.90 (16-1)	5.47 (17-11)	6.07 (19-11)
G Minimum swing radius	m (ft-in)	3.76 (12-4)	3.71 (12-2)	3.60 (11-10)
Bucket rotation	deg.	183°	183°	183°
Dipper tearout (ISO 6015)	kgf (lbf)	13450 (29650)	11560 (25485)	9590 (21142)
Dipper tearout with boost (ISO 6015)	kgf (lbf)	14610 (32210)	12550 (27670)	10410 (22950)
Bucket tearout (ISO 6015)	kgf (lbf)	14550 (32080)	14550 (32080)	14550 (32080)
Bucket tearout with boost (ISO 6015)	kgf (lbf)	15800 (34835)	15800 (34835)	15800 (34835)

STANDARD EQUIPMENT

Engine fan guard; Cold start pre-heat; Auto engine warm up; Double element air cleaner; Electric refuelling pump; Heavy-duty alternator; Electrics isolator; Heavy-duty batteries; Cab & engine soundproofing; Cab heater & screen demister; Tinted glass; Interior light; Coat hook; Operator's storage shelf; Removable floor mat; Windscreen wash/wipe; Plug-in power socket; Automatic power boost; Auto-idle; One-touch engine speed control; Hydraulic cushion control; Boom/swing priority switch; Plexus hydraulic oil filtration; HSP pressure test points; Auxiliary pipework mounting brackets; Work lights – boom & mainframe mounted; Undercarriage belly guarding; Upper structure under covers; Swing system cover; Twin track guides; External mirrors; Handrail & non-slip walk ways; Quick connect engine oil drain pipe; Front screen blind; Quick connect fuel tank drain pipe; Hinged engine under cover; Remote filter system.

OPTIONAL EQUIPMENT

Hose burst check valves & overload warning system; Tipping link mounted lift points; General purpose buckets; Ditch/grading buckets; Quickhitch buckets; Hydraulic hammers; Auxiliary pipework (full and low flow); Climate control; Cab mounted & rear work lights; Rotating beacon; Rain guard; Biodegradable oil; Air suspension seat with heated pad and lumbar support adjustment; lower screen wiper; Radio; High and low temperature hydraulic oil option.

GENERAL PURPOSE EXCAVATOR BUCKETS

All buckets are JCB – Esco type fully welded steel, with sealed, hardened steel pivot pins and replaceable wear parts.

Max Width	Capacity (SAE heaped)	Weight
600mm (24in.)	0.40cu.m (0.52cu.yd)	484kg (1067lb)
900mm (36in.)	0.71cu.m (0.93cu.yd)	595kg (1312lb)
1000mm (39in.)	0.81cu.m (1.06cu.yd)	627kg (1382lb)
1200mm (47in.)	1.03cu.m (1.35cu.yd)	705kg (1555lb)
1350mm (53in.)	1.05cu.m (1.37cu.yd)	679kg (1497lb)
1450mm (57in.)	1.14cu.m (1.49cu.yd)	720kg (1588lb)
1500mm (59in.)	1.19cu.m (1.56cu.yd)	734kg (1618lb)

ATTACHMENTS

Surelock Hydraulic Quickhitch

Hammermaster HMI570Q, HMI760Q

GP Buckets Cat style teeth – 610mm, 762mm, 914mm, 1067mm, 1219mm
ESCO tooth system – 550mm, 850mm, 950mm, 1150mm, 1300mm, 1400mm, 1450mm

Heavy-duty Buckets ESCO tooth system – 550mm, 850mm, 1150mm, 130mm

Grading Buckets 1542m, 1830mm, 2058mm

Selector Grab SG700 – capacity 700l











Rockwheel RW100N – 1058mm (42in) cutting width

Multiprocessor MP200

Crusher Bucket CB70 30m³/h











LIFT CAPACITIES – Dipper length: 1.9m, Monoboam 5.7m, Trackshoes: 700mm, No bucket.

JS210 LC MONO

Reach	3m (9ft 10in)		4.5m (14ft 9in)		6m (19ft 8in)		7.5m (24ft 7in)		Max. Reach		Max. Reach
											
Load Point Ht.	kg	kg	kg	kg	kg	kg	kg	kg	kg	kg	mm
6.0m (19.8ft)					6380*	4990			5720*	4850	6105
4.5m (14.9ft)			8020*	7450	6720*	4890			5700*	3950	6907
3.0m (9.10ft)			9870*	6960	7470*	4700			5820	3550	7318
1.5m (4.11ft)			11210*	6610	7660	4520			5640	3420	7406
0m			11510*	6500	7540	4430			5840	3520	7182
- 1.5m (- 4.11ft)	13010*	12440	11040*	6520	7540	4420			6570	3920	6614
- 3.0m (- 9.10ft)	12760*	12620	9650*	6660					7600*	4970	5596
- 4.5m (- 14.9ft)											











LIFT CAPACITIES – Dipper length: 2.4m, Monoboam 5.7m, Trackshoes: 700mm, No bucket.

JS210 LC MONO

Reach	3m (9ft 10in)		4.5m (14ft 9in)		6m (19ft 8in)		7.5m (24ft 7in)		Max. Reach		Max. Reach
											
Load Point Ht.	kg	kg	kg	kg	kg	kg	kg	kg	kg	kg	mm
7.5m (24.7ft)									5230*	5230*	5547
6.0m (19.8ft)					5810*	5080			4790*	4180	6767
4.5m (14.9ft)			7330*	7330*	6290*	4950			4690*	3520	7497
3.0m (9.10ft)			9230*	7090	7110*	4740	5630	3450	4800*	3200	7878
1.5m (4.11ft)			10820*	6690	7680	4550	5540	3360	5080	3090	7959
0m			11480*	6510	7540	4420	5470	3300	5230	3170	7751
- 1.5m (- 4.11ft)	10850*	10850*	11300*	6490	7500	4380			5760	3460	7229
- 3.0m (- 9.10ft)	14090*	12470	10270*	6580	7560*	4460			6980*	4190	6313
- 4.5m (- 14.9ft)			7500*	6850					6850*	6320	4777

LIFT CAPACITIES – Dipper length: 3.0m, Monoboam 5.7m, Trackshoes: 700mm, No bucket.

JS210 LC MONO

Reach	3m (9ft 10in)		4.5m (14ft 9in)		6m (19ft 8in)		7.5m (24ft 7in)		Max. Reach		Max. Reach
											
Load Point Ht.	kg	kg	kg	kg	kg	kg	kg	kg	kg	kg	mm
7.5m (24.7ft)					4350*	4350*			3440*	3440*	6285
6.0m (19.8ft)					5170*	5170			3210*	3210*	7382
4.5m (14.9ft)					5740*	5020			3160*	3160*	8056
3.0m (9.10ft)	11580*	11580*	8380*	7240	6630*	4800	5190*	3570	3230*	2920	8411
1.5m (4.11ft)			10200*	6780	7560*	4570	5540	3360	3430*	2820	8488
0m	6400*	6400*	11240*	6510	7540	4410	5450	3280	3800*	2870	8293
- 1.5m (- 4.11ft)	10510*	10510*	11410*	6430	7450	4340	5420	3250	4470*	3090	7807
- 3.0m (- 9.10ft)	15320*	12250	10770*	6470	7480	4360			5790*	3620	6969
- 4.5m (- 14.9ft)	12460*	12460*	8920*	6650					6760*	4930	5619

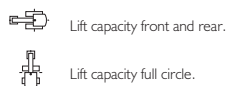

- Notes:
1. For lifting capacity including bucket, subtract total weight of bucket or bucket and quickhitch from above values.
 2. Lifting capacities are based on ISO 10567, that is: 75% of minimum tipping load or 87% of hydraulic lift capacity, whichever is the less. Lifting capacities marked* are based on hydraulic capacity.
 3. Lift capacities assume that the machine is on firm, level ground.
 4. Lift capacities may be limited by local regulations. Please refer to your dealer.



Hydraulic Excavator JS210 LC Engine Power: 128kW (172hp) Bucket Capacity: 0.40 – 1.19m³ Operating Weight: 21144 – 22490kg

JCB Sales Limited, Rocester, Staffordshire, United Kingdom ST14 5JP. Tel: +44 (0)1889 590312.

Download the very latest information on this product range at: www.jcb.com

©2009 JCB Sales. All rights reserved. No part of this publication may be reproduced, stored in a retrieval system, or transmitted in any form or by any other means, electronic, mechanical, photocopying or otherwise, without prior permission from JCB Sales. JCB reserves the right to change specifications without notice. Illustrations and specifications shown may include optional equipment and accessories. The JCB logo is a registered trademark of J.C. Bamford Excavators Ltd.

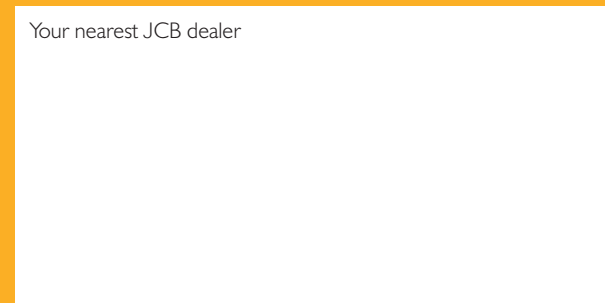

Mixed Sources
Product group from well-managed
forests and other controlled sources
www.fsc.org Cert no. TC-COC-002291
© 1996 Forest Stewardship Council



**WORLD
LAND
TRUST™**

www.carbonbalancedpaper.com
unique print number